

**AXPERT Eazy<sup>mini</sup>**  
**SERIES VFD**

General Purpose  
Advanced User  
Friendly VFD



CE

Range: 400 V System (380...480 V)  
1...10 HP (0.75...7.5 kW)

### Features

- **Control Modes**
  - V/f open loop control
  - Sensor-less vector control
- **Intelligent**
  - User-programmable built-in PLC
  - PID control
  - Multi-pump control
- **Environment-friendly**
  - Selectable Soft-sound switching frequency
  - High-efficiency operation
- **Human Machine Interface**
  - LED display as standard
  - 128x64 Graphical LCD Display with white back light and RTC (Optional)
- **Field Bus**
  - Modbus RTU interface
- **Safety Input**
  - Safe Torque OFF (STO) function
- **Designed for Harsh Environment**
  - 122 °F (50 °C) ambient temperature
  - State of the art conformal coating to protect PCBs against 3C3 environment
- **Application Specific Features**
  - Conveyor
  - Centrifuge
  - Fermentor
  - Pump
  - Compressor
  - Fan
  - Crane/Hoist
  - Pump Jack (Artificial Lift)

# Standard SPECIFICATIONS

Model	Frame	Weight	Input Voltage 441...480 V (Nominal 460 V)						
			Input Current	Output Rating					
				No Overload Rating		Normal Duty Rating		Heavy Duty Rating	
kg	A	A	HP	A	HP	A	HP		
AMT-EM-02A6-4	P3	3.3	1.9	2.5	1	2.4	1	2.4	0.75
AMT-EM-03A3-4	P3	3.3	2.8	3.2	1.5	3	1.5	2.5	1
AMT-EM-004A-4	P3	3.3	3.8	3.8	2	3.6	2	3.2	1.5
AMT-EM-05A8-4	P3	3.3	5.6	5.5	3	5.2	3	4.5	2
AMT-EM-008A-4	P3	3.4	7.6	7.6	4	7	4	5.5	3
AMT-EM-010A-4	P3	3.4	10.1	9.5	5	9	6	7.6	4
AMT-EM-014A-4	P3	3.4	14	13	7.5	12	7.5	10.5	5
AMT-EM-018A-4	P3	3.5	19	17	10	16	10	13	7.5

Power Rating	Mains supply voltage	-4: 380...480 VAC (nominal voltage 415 VAC), 3-Phase, 3-Wire, -15%, +10%
	Mains supply frequency	50 Hz, 60 Hz or 50/60 Hz, +/- 3 Hz
	Input current	As per above table
Control Functions	Output current	Nominal output current available continuously, No overload allowed 120% for 60 seconds, 140% for 2.5 seconds every 5 minutes, Normal Duty (ND) use 150% for 60 seconds, 175% for 2.5 seconds every 5 minutes, Heavy Duty (HD) use
	Control Method	Digital Space Vector PWM Control
	Control Mode	V/F Open Loop, Vector Control Open Loop
	Frequency Range	0.10...599.00 Hz for V/F Control
	Frequency Accuracy	Digital references: ±0.01% (0...50 °C) / Analog References: ±0.01% (0...50 °C)
	Output Frequency Resolution	0.0001 Hz (20-bit)
	Frequency Setting Resolution	0.01 Hz Digital, 0.012 Hz/ 50 Hz Analog (12-bit)
	V/ Hz Characteristics	2-Preprogrammed patterns, 1-Custom 3-point setting pattern
	Torque Boost	Manual/Automatic Selective: 0...20%
	Acceleration/Deceleration Time	0.1-6,00,000 Seconds, Linear or S-Curve selective
	Skip Frequency	Three frequencies can be set, band can be set up to 10.0 Hz
Slip Compensation	Slip compensation frequency up to 5.0 Hz	
Carrier Frequency <sup>1</sup>	Default: 5 kHz, 1...10 kHz Settable	
Operation Specifications	Speed Search Function	Allows the drive to start with rotating machine without damage / tripping.
	Kinetic Energy Buffering	In case of momentary power fluctuations allows the drive to run using the kinetic energy of the load, accelerates to the set speed when power resumes
	Power Loss Carry Through	Up to 5 seconds for smooth operation of system during power loss with no output torque
	DC Braking	DC Braking start frequency 0.1...50.0 Hz, Time: 0...25 seconds, Brake current: 15...150%
	Dynamic Braking Circuit	In-built
	Dynamic Braking Resistor	External (Optional)
	Frequency / Torque Setting Input	Digital Operation Panel (Keypad) Analog Input: 2 k Ohm Potentiometer, Programmable Analog Inputs Digital Input: Static Pot (Frequency Increase/ Frequency Decrease), Preset Speeds (Preset input0, 1 & 2) Serial: RS-485 Built-in PLC: PLC Analog output1 & 2
I/O Specifications	Auto Restart	Adjustable up to 10 times, selectable for different faults
	PID Controller	Inbuilt PID controller can be used as stand alone. PID Signals can be scaled and assigned with actual process parameter units
	Analog Inputs	2 Analog Programmable Inputs with settable Gain, Bias, Minimum and Maximum scaling AI1 & AI2: 0...10 Vdc / 4...20 mA
	Digital Inputs	6 Digital Inputs, Sink (NPN) / Source (PNP) and Active Close / Active Open selectable Programmable options: Not Used, Jog Select, Ramp Select, Preset I/P0, Preset I/P1, Preset I/P2, Freq Increase, Freq Decrease, Aux Drive, Emergency Stop, Fault Reset, External fault1, External fault2, Reverse, Terminal, Ref Select0, Ref Select1, PR Step Skip, PR Step Hold, PR/RSF Reset, PID Bypass, PID Disable, Run, Stop, Drive Enable, PLC input1, PLC input2, PLC input3, PLC input4, PLC input5, PLC input6, Torque mode, Ready1 F/B, Forward Run, Reverse Run, Forward Jog, Reverse Jog and MBRK Answer, Motor PTC
	Safety Inputs	1 Digital Input for Safe Torque Off (STO) function to comply with Safety Integrity Level 2 (SIL2), +24V Sink logic
	Digital outputs	2 Digital Outputs, open collector type and Active Close / Active Open selectable Programmable options: Not Used, Local, Run, Forward Run, Reverse, Reverse Run, I-Detection1, I-Detection2, Freq Attain, Speed Detect1, Speed Detect2, Acceleration, Deceleration, Aux Drive, Timer Output, Zero Speed, Fault Alarm, PID Up Limit, PID Lo Limit, Temp Alarm, Ready, Ready1, Pump1, Pump2, Pump3, Pump4, Doff-End Alarm, Sleep Mode, Fault, PLC O/P1, PLC O/P2, PLC O/P3, PLC O/P4, PID F/B Upper Limit, PID F/B Lower Limit, Fan Control, MBRK1, MBRK2, MBRK3, KEB ON, Overload fault, Overcurrent fault, Earth fault, Over temperature fault, Overvoltage fault, STO, On Time1, On Time2 and On Time3
	Potential Free Contacts	2 Relays, 1-NO, 1-NC for 5 A @ 240 VAC Programmable options same as digital outputs
	Analog Outputs	2 Analog Outputs with settable Gain, Bias, Minimum and Maximum scaling AO1 & AO2: 0...10 Vdc / 4...20 mA Programmable options: Output frequency, Motor output current, Output power, Output voltage, DC bus voltage, PID output, IGBT temperature, PLC AO1, PLC AO2, Unipolar torque current, Excitation current, Set frequency, Bipolar torque current, Motor OL, Drive OL, Drive output current, Test 0% and Test 100%
Network connectivity	RS-485 for PC Interface with Modbus-RTU protocol connectivity as standard	

# Standard SPECIFICATIONS

Display	LED Display and Keypad unit	Digital Operation Panel 5 digit seven segment LED display with 2 decimal points, Unit indication, Motor direction, Start control and Drive's status LEDs display, 9-Key Keypad, 3-Status indicating LED for Run, Stop, Fault. 12 predefined normal parameter display
	Graphical Display and Keypad unit (Optional) with RTC	Digital Operation Panel 128x64 Graphical LCD with white back light LED, 9-Key Keypad, 3-Status indicating LED for Run, Stop, Fault   Real Time Clock Simultaneous display of 8 selectable monitor parameters Two graph screens with selectable graph signal and resolution Load Analyzer screens   Auto rotation of screens with settable time interval
Protective Specifications	Protective Function	Overcurrent fault, Drive overload fault, Motor overload fault, DBR overload fault, Undercurrent fault, DC Bus Overvoltage fault, DC Bus Undervoltage fault, Temperature fault, Input & Output phase loss fault, Earth (Ground) fault, External fault, Charging fault, Current sensor fault, EEPROM fault, 4...20 mA Reference missing fault, Auto tuning fault, Emergency stop, Communication loss, Output unbalance current fault, Speed deviation fault, Overspeed fault, Motor overtemperature fault, IGBT Driver fault, Watchdog fault, Control Power fail fault etc.
	Smooth Operation	Current Limit, Speed Search, Auto Restart (with individual fault selection), Power Loss Carry Through (PLCT), Kinetic energy buffering (KEB) and IGBT overtemperature alarm functions
	Diagnosis Functions	Helps in pinpointing the fault. Diagnosis Mode, Load Analyzer1, Load Analyzer2, Peak Monitoring, Number of Power On, Overtemperature fault, Overvoltage fault, Overcurrent fault, Earth fault, Overload fault, Auto restart monitoring, 3 warning timer for maintenance and Debug Mode for logic verification
	Fault history	Last 20 faults stored with status and 8 operational parameters (Output frequency, Output current, DC bus voltage, IGBT temperature, Output Power, Total power ON time, kWh, MWh). Date and Time will also be saved in Graphical Display.
Environment	Installation location	Indoor
	Vibration	As per EN 60068-2-6, Acceleration: 1g, Frequency: 10...150 Hz
	Ambient temperature	14...122°F (-10...50°C)
	Storage temperature	14...158°F (-10...70°C)
	Altitude (above sea level)	3300 ft (1000 m) without derating, above this derate 5% per 1000 ft (305 m)
	Relative Humidity	0...95% maximum non-condensing
Enclosure	IP20	
Reference Standards	UL 508C, UL 61800-5-1, CSA C22.2 NO. 274-17, IEC 61800-5-1, CE (EN 50178:1997, EN 61800-3:2004+A1:2012, EN 61800-5-1:2007), EN 61800-5-2:2007	

- 1) If the default carrier frequency is exceeded, derate the output current by 5% per 1 kHz as the reduced rating.
- 2) The input power factor is considered approximately 0.6 and motor efficiency 85% for the input current calculation. The inverter efficiency is >98%.  
The input power factor is approximately 0.9 when input choke of 3% rating is used.
- 3) The output current indicates the total effective value including the higher harmonics.
- 4) The kW shown is maximum applicable motor output for a 4-pole standard induction motor.

## Connections & TERMINALS & DISPLAY

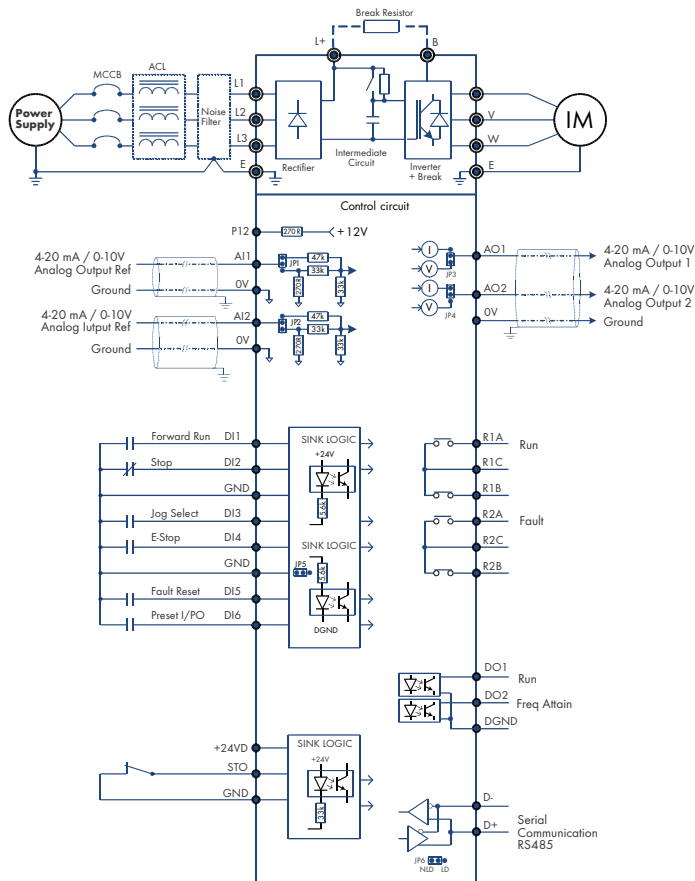

## Dimension

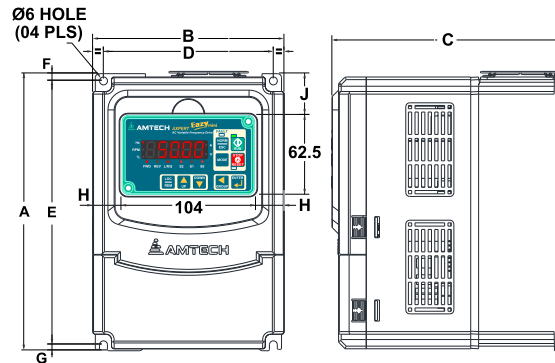

Frame	Dimensions in inch (mm)									
	A	B	C	D	E	F	G	H	J	
P3	8.34 (212)	5.70 (145)	6.85 (174)	5.08 (129)	7.87 (200)	0.21 (5.5)	0.17 (4.5)	0.84 (21.5)	1.24 (31.5)	

## Display Options

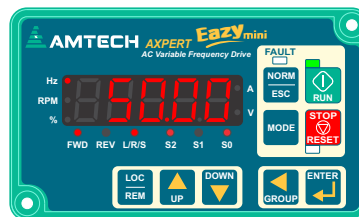

LED Display (Standard)

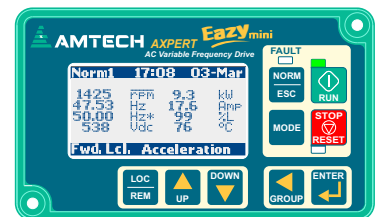

Graphical LCD Display (Optional)

# Our Other Offerings

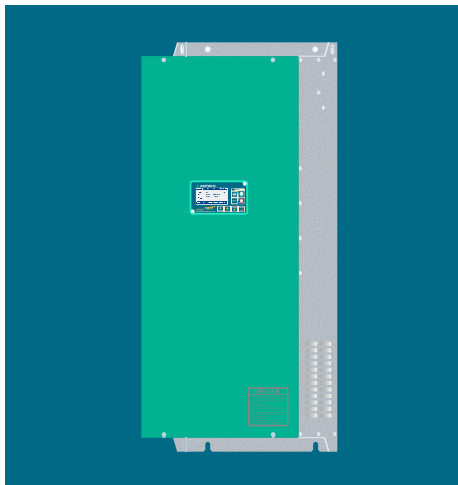

## AXPERT Eazy+ SERIES VFD

The **Next Generation Axpert-Eazy+ Series VFD** is the outcome of Amtech's decades of experience in motor control and automation.

The Low loss, High efficiency Industrial Grade New Series is designed to meet the ever increasing expectations of our customers; deliver highest performance, protection and energy saving without compromising the user friendliness.

### Models:

**400V : 1 to 2700 HP (0.75 to 2000 kW)**

**500V : 40 to 2500 HP (30 to 1800 kW)**

**600V : 50 to 2900 HP (37 to 2100 kW)**

### Features:

- Highly efficient 7<sup>th</sup> Generation IGBT and Capacitors
- Fully configurable digital and analog I/Os & functional safety function (STO)
- Wi-Fi and RS-485 Modbus communication as standard
- 128x64 Graphical LCD Display with white back light and RTC
- Easy to diagnose with diagnosis functions

### Applications:

- Pumps, Blowers, Fans
- Agitators & Conveyors
- Compressors, Centrifuges
- Paper & Pulp
- Oil & Gas
- Mining



## ADAPT SYSTEM PUMP JACK SOLUTION

Amtech Drives offers the ultimate solution in SRP (Sucker Rod Pump) control, the most common forms of reciprocating artificial lift system employed by Oil and Gas companies worldwide.

Amtech offers solutions in all the processes of Upstream, Midstream and Downstream in Oil & Gas industry.

### Models:

**400V : 5 to 100 HP (3.7 to 75 kW)**

### Features:

- Factory-tested Integration
- Simplified setup
- Smooth starting & operation of system
- Lower impact on piping/valve system, longer equipment life and less maintenance
- Unique algorithm for torque control and no need of braking resistors

### Applications:

- Oil well pumpjack



## ENGINEERED SYSTEMS

Our vertically integrated engineered systems assures seamless co-ordination between individual components in our complete packaged solutions.

The packages comprise VFD modules with customer specific switchgear & protection, enclosure requirements and cooling arrangements. The seamless integration guarantees that performance specifications are adhered to as per the ratings, enclosure types, environmental issues and power supply conditions.

### Advantages:

- Global compliances UL, cUL, CSA and CE
- Normal duty & heavy duty ratings
- UL panel shop
- Energy efficient systems
- Can be built to your specification

### Customized Applications:

- Bypass Solutions for Critical Applications
- Redundant System
- Low Harmonic Solutions

Specifications in this catalog are subject to change without notice.

CAT.NO. : ADI/EAZY MINI/01-26



**Amtech**  
DRIVES

745 Trabert Ave NW  
Atlanta, GA. 30318  
Phone : (770) 8AMTECH  
          : (770) 826-8324  
E-mail : info@amtechdrives.com  
URL : www.amtechdrives.com

